

APPENDIX J

**DREDGE AND CAPPING EQUIPMENT SELECTION AND
PRODUCTION RATES**



M E M O R A N D U M

DATE: October 28, 2010

TO: Dave Smith and Ed Glaza, Parsons

FROM: Mike Crystal, Sevenson Environmental Service
Tim Donegan, PE, Gahagan and Bryant Associates, Inc.

RE: Onondaga Lake Dredge Selection and Anticipated Production Rates

Hydraulic Dredges

Sevenson plans on having three dredges on site for the Onondaga Lake Project. Two of the dredges will be available for performing the majority of the dredging - these are referred to herein as “production dredges” (Dredge 1 and Dredge 2). The third dredge will be available for dredging in shallow water, confined areas, or other unique conditions – this dredge is referred to herein as a “specialty dredge” (Dredge 3). Sevenson’s two production dredges are each capable of handling the required daily production to meet the project schedule, thus providing buffer capacity in case of emergency needs. The third dredge will be a small specialty dredge that can be used simultaneously with the smaller of the two “production” dredges and will be operating in the vicinity of shorelines and highly vegetated areas. These dredges have been selected to maximize dredge production and efficiency for the variable site conditions.

Dredge selection criteria included:

- Capability to operate efficiently at a maximum of 5,500 gallons per minute (GPM) of slurry flow
- Capability to efficiently dredge material with a standard penetration test (SPT) blow count of 25 blows per foot (Highest recorded blow counts in Remediation Areas, Remediation Area D ILWD material)
- A large dredge (production dredge) that can efficiently remove large faces (cuts) of material (i.e. 3-foot cut)
- Small dredge (specialty dredge) that can efficiently remove shallow face material (i.e. 0.5-foot)
- Larger dredges (production dredge) that have the capability to pump long distances to the shoreline without additional boosters on the water
- Capability to operate in shallow water and nearshore areas
- Provide redundancy in the dredging operations if one dredge needs to shut down for mechanical/maintenance reasons (i.e. a second dredge capable of achieving project production rates would be available for immediate use)

- Capability to dredge up to the water surface without cavitation of the pump or vortex suction of air (i.e. nearshore areas where part of the cutterhead might be out of the water)
- Capability for dredge (or combination of dredges) to meet the project goal of completing the dredging in 4 years
- Capability to handle debris and submerged aquatic vegetation (SAV) by the use of cutting knives, shrouds, and possibly a “gatling plate”

The factors described above led to the decision by Severson and the design team to identify three dredges that will be used at the site. The two proposed “production dredges” are a 16-inch-diameter and 14-inch-diameter dredge, and the “specialty dredge” is an 8-inch-diameter dredge. The estimated removal rate of either “production dredge” could meet the required project objectives; however, to provide additional production capacity and buffer during environmental dredging, the recommendation to have two large production dredges and one smaller specialty dredge will enable the project to be completed efficiently.

Severson plans to use the 16-inch production dredge (Dredge 1), which can operate at a continuous flow of 5,500 GPM, during stand-alone operations. This dredge will not be used in combination with any of the other dredges. The 14-inch production dredge (Dredge 2) can be used alone (pumping 5,500 PGM) or in combination with the 8-inch specialty dredge (Dredge 3). If Dredges 2 and 3 are operated at the same time, flow for each dredge will be limited for a combined total of 5,500 GPM of slurry. The flow for the 14-inch dredge will be limited to 4,000 GPM and the flow for the 8-inch dredge will be limited to 1,500 GPM. The two dredge lines will join each other through a Y-valve connection prior to the on land booster. Dredge discharge piping will enter booster pump #1 where it will be transported up to the SCA via the 16-inch/22-inch dual wall high density polyethylene (HDPE) sediment transport pipe. If additional water is required for the slurry pipeline, the booster pump will automatically open a valve allowing “makeup” from the lake to enter the pipe system and to keep the flow at 5,500 GPM.

Dredge Specifications

The specifications for the three dredges are described below.

Dredge 1 – 16-inch-diameter Dredge “Marlin” (Dredging Supply Company Series 7650D)

- Overall dredge length: 104-feet including ladder in the up position
- Overall dredge width: 40-feet
- Hull dimensions, excluding ladder; length: 70-feet, width: 40-feet, depth: 5-feet, draft: 3-feet
- Spud carriage barge measuring 30-feet long by 10-feet wide with a 10 foot stroke
- Dredge will set forward using 1 spud centered in the stern
- Capable of dredging a 2 foot cut in shallow water
- Extended ladder for a maximum dredge depth of 56-feet below the water surface
- Impeller diameter: 40-inches
- 16-inch suction (inside diameter - ID) and 16-inch discharge (ID)
- Cutter diameter: 43-inches
- Installed power: 800 horsepower (Hp)
- Cutter motor power: 130 Hp
- Hospital grade muffler installed for added noise reduction



Figure 1. Dredging Supply Company 16-inch-diameter Dredge “Marlin”

Dredge 2 – 14-inch-diameter Dredge “Shark” (Dredging Supply Company Series 75450D)

- Overall dredge length: 68-feet including ladder in the up position
- Overall dredge width: 20-feet
- Hull dimensions, excluding ladder; length: 40-feet, width: 19-feet, depth: 4-feet, draft: 2-feet
- Spud carriage barge measuring 30-feet long by 10-feet wide with a 10 foot stroke.
- Dredge will set forward using 1 spud centered in the stern
- Extended ladder for a digging depth of 43-feet below the water surface
- Impeller Diameter: 36-inches
- 14-inch suction (ID) and 14-inch discharge (ID)
- Cutter diameter: 34-inches
- Installed power: 700 Hp
- Cutter motor power: 90 Hp
- Hospital grade muffler installed for added noise reduction



Figure 2. Dredging Supply Company 14-inch-diameter Dredge “Shark”

Dredge 3 – 8-inch-diameter Dredge “Moray” (Dredging Supply Company Series 2000)

- Overall dredge length: 42-feet including ladder in the up position
- Overall dredge width: 11-feet
- Hull dimensions, excluding ladder; length: 35-feet, width: 11-feet, depth: 4-feet, draft: 1.5-feet
- Dredge can operate in swinging ladder mode or conventional mode
- Impeller Diameter: 20-inches
- 8-inch suction (ID) and 8-inch discharge (ID)
- Cutter diameter: 28-inches
- Installed power: 275 Hp
- Cutter motor power: 20 Hp
- Hospital grade muffler installed for added noise reduction



Figure 3. Dredging Supply Company 8-inch-diameter Dredge “Moray”

Operational Plan

Sevenson plans to use Dredge 1 (16-inch Marlin Class) as the primary production dredge. The dredging production rate for this dredge will be at its highest when operating in Remediation Areas D and E, where over 75% of the targeted dredge volume for the Onondaga Lake Project is located. Specifically, the dredge plan in Remediation Area D includes up to a 9-foot face of material that will yield the highest production rate. The production of Dredge 1 is most efficient (i.e., highest production rate) when working in areas with large faces to cut (>3.5 feet). The actual operating thickness of each dredging pass will be dependent on material types encountered. Material passes can range from 1 foot up to 3.5 feet. An average cut thickness will be approximately 2 feet. Softer materials will allow thicker cuts possibly using the entire height of the cutterhead. Therefore a 9-foot face offers a large quantity for optimal dredge efficiency.

Dredge 2 (14-inch Shark Class) will serve as a backup dredge, and can also be used as a primary production dredge if conditions (i.e. water depths, swing configuration, etc.) do not allow Dredge 1 to operate or when Dredge 3 is needed for nearshore dredging. As mentioned earlier, Dredge 2 will work in tandem with Dredge 3 to maximize slurry transport volumes.

Dredge 3 (8-inch Moray Class) will be used in neashore areas or in areas where small face cuts are required. Dredge 3 operating by itself will not generate enough water to maintain an adequate flow volume/velocity within the dredged material pipeline to transport the slurry. Therefore, Dredge 2 was specifically designed to operate simultaneously with Dredge 3 providing enough combined flow to adequately transport the slurry yet within the limits of the maximum flow criteria of 5,500 GPM that the sediment management and water treatment operations can manage. Coordination with Dredge 1 and Dredge 2 will be needed to maintain scheduled production rates.

Hydraulic Dredge Instrumentation

Each hydraulic dredge will be fitted with a DeltaMass MT Series Mass Flow and Density Sensor (one unit). The DeltaMass flow meter combines a magnetic flow meter and a low-level gamma ray density sensor for measuring the density of the slurry and the flow rates, which together provide the instantaneous production rate of material being removed. This information will be visible to the operator so that he can control the flow in the pipeline to achieve a uniform slurry. Output from these two gauges will be fed into a “Totalizer Unit”, which will keep track of the total quantity of material dredged in real-time.



Figure 4. Delta Mass Instrument

GPS Equipment

Sevenson will use a new Real Time Kinematic Global Positioning System (RTK) GPS (Trimble 461 with heading) system designed and installed for the Onondaga Lake project. The Dredgepack software, which was designed for use with an excavator and/or the hydraulic dredges, will compile the information from the GPS and other positioning equipment on the dredges (e.g., inclinometer, tilt sensors, etc.), to track the horizontal and vertical position of the dredge cutterhead or excavator bucket in real-time throughout the project.

Calibration of the system will be performed by comparing water level and x, y position derived by the Dredgepack software with independent values derived from a Trimble S6 robotic total station positioned on shore with millimeter accuracy.

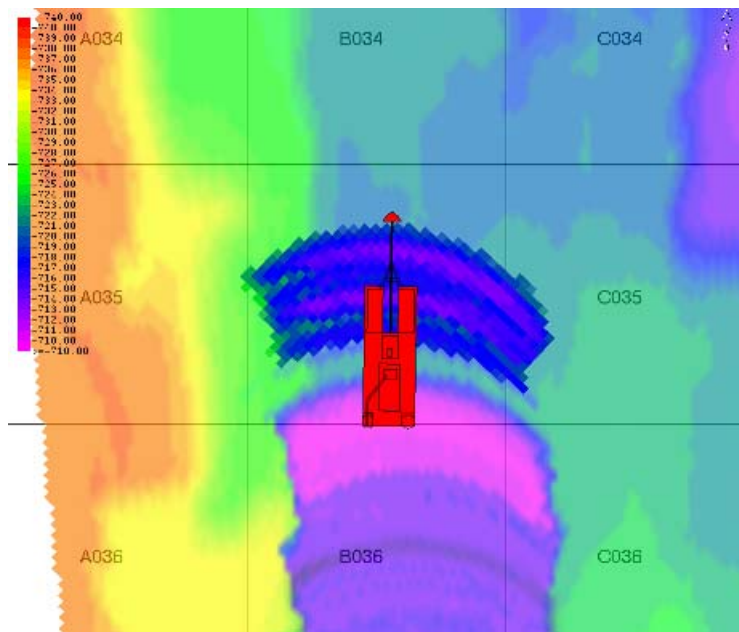

Figure 5. Example Output from Dredgepack for a Hydraulic Dredge

The information that the dredge captain looks at on the screen will be remotely broadcast back to the shoreline office trailer via cellular modem. All information collected on the dredge (e.g., dredge position, real-time swing, etc.) will be broadcast real-time in the office trailer. This remote transmitting can also be used to service the software if a problem occurs or a setting needs to be changed. The positional information will also be logged at the dredge for viewing at a later date to verify where the dredge cutterhead had traveled.

Hydraulic Dredge Production

Production rates for the proposed dredge system were developed with the understanding of a flow limitation of 5,500 gallons per minute that can be delivered to the SCA.

Tables 1 through 4 below provide a summary of estimated production rates for each dredge and combination of dredges. The production rates were developed using propriety software developed by Dredging Supply Company (DSC) based on the in-situ geotechnical data, available blow count data (SPT borings), dredge characteristics (i.e. impeller diameter/horsepower), swing speed, swing distance, time required to advance the dredge and handle anchors, pumping distances to the first available booster pump, and booster pump spacing along the proposed alignment.

Table 1 –Summary of Estimated Production Ranges for Remediation Areas for Dredge 1 – Marlin 16-inch-Diameter

Remediation Area	Size (Acres)	Marlin Production (CY/HR)	Marlin % Solids (dry weight basis)
A	27.1	338	16
B	5.9	178	9
C	4.9	216	11
D	89	351	12
E	91.9	342	19

Table 2 –Summary of Estimated Production Ranges for Remediation Areas for Dredge 2 – Shark 14-inch Diameter

Remediation Area	Size (Acres)	Shark Production (CY/HR)	Shark % Solids (dry weight basis)
A	27.1	215	11
B	5.9	159	8
C	4.9	203	10
D	89	224	8
E	91.9	218	12

Table 3 –Summary of Estimated Production Ranges for Remediation Areas for Dredge 3 – Moray 8-inch Diameter

Remediation Area	Size (Acres)	Moray Production (CY/HR)	Moray % Solids (dry weight basis)
A	27.1	30	6
B	5.9	24	5
C	4.9	22	5
D	89	38	5
E	91.9	30	7

Table 4 –Summary of Estimated Production Ranges for Remediation Areas for Dredges 2 and 3 Operating Simultaneously – Shark 14-inch Diameter and Moray 8-inch-Diameter with a Maximum Flow Rate of 5,500 GPM.

Remediation Area	Size (Acres)	Shark and Moray Combined Production (CY/HR)	Shark and Moray Combined % Solids (dry weight basis)
A	27.1 AC	245	12
B	5.9 AC	183	9
C	4.9 AC	225	9
D	89 AC	262	9
E	91.9 AC	248	14

All production rates shown in the four tables above are considered estimates and account for handling of anchors, fueling, mechanical maintenance, and movement of the dredge amongst the Remediation Areas.



DATE: November 3, 2010

TO: Dave Smith and Ed Glaza, Parsons

**FROM: Mike Crystal, Sevenson Environmental Service
Tim Donegan, PE, Gahagan and Bryant Associates, Inc.**

RE: Onondaga Lake Capping Anticipated Production Rates

Sevenson's approach to placement of sand materials and stone materials smaller than 2 inches in diameter will involve a hydraulic slurry system. It is anticipated that armor (rock/gravel) materials larger than 2 inches in diameter will be placed using a hydraulic excavator with real-time kinematic (RTK) global positioning system (GPS). Placement approaches are discussed below.

SAND AND ROCK CAPPING OPERATIONS

Sevenson will use our custom-built slurry system for hydraulic placement of the sand cap and stone armor less than 2 inches in diameter in designated areas. The system consists of a feed hopper, oversized screening, and slurry system that will pump the sand and small stone hydraulically through a pipeline for placement through a diffuser system on a barge. The pump used to convey the sand slurry is a booster type pump commonly found on dredging projects. The hopper, screening, and slurry system will be placed on the shoreline at two potential locations to minimize pumping distances and the need for booster pumps floating on the water. The two preliminary locations have been identified on Wastebed B and Wastebeds 1-8 and will be coordinated with upland sites and finalized in a future submittal.

The following criteria were considered in selecting equipment for the placement of sand and armor materials as part of the Onondaga Lake caps:

- Minimize multiple handling of materials, extra equipment, and personnel required for placement of sand and rock materials.
- Capability to hydraulically convey sand and small armor stone materials from nearshore location to the farthest points of the lake while maintaining production
- Capability to pump armor stone material up to 2-inches in diameter
- Access to shallow water (i.e. less than 1-foot of water) and still efficiently spread/place materials
- Portable system that can be broken down and relocated
- Design a system with redundancy and capacity to meet production is one system goes down.

The considerations described above led to the decision by Sevenson and the design team to select to hydraulic spreader systems that will meet the schedule and maintain production rates.

A 20-foot by 40-foot diffuser/spreader barge will be attached to the slurry system by the 16SDR11 high-density polyethylene (HDPE) pipe. The spreader system will be attached to the 20 foot side of the barge. This barge will have a waterfall type discharge apparatus (steel plate angled towards the water) fabricated on the deck (Figure 1). The angled discharge plate will act to dissipate the energy in the capping material slurry delivered to the placement barge via the floating line. Therefore, the sand cover will enter the water in a controlled fashion with minimal fall velocity. The diffuser barge will have a hydraulic cable winch system and anchors to facilitate the movement of the barge for placement of the material. The anchor system will be designed to minimize cable sweep across the cap surface with the use of cable floats and cable tensioning sensors on each winch drum. Two spreader barges will be on site operating at the same time as required.

The armor stone spreader system (Figure 2) is composed of a similar flexi float system but with a different diffuser head. The armor stone diffuser spreader system is composed of 4 energy dissipation boxes. With angled plates welded to the interior. The armor stone slurry enters the 4 boxes and separates the flow in half. The slurry flow is separated into 8 different flows. Materials are dropped vertical into the water for an even distribution.

The pump system is composed of a 900 HP dredge pump with a 38-inch-diameter impeller and two 8-inch-diameter Godwin pumps to deliver the slurry make up water into the mixing tank located next to the stockpiles at each potential staging location. A dedicated slurry system will be utilized for each capping operation. There is a possibility that one system will be spreading armor stone while the second system is spreading sand.



Figure 1. SES Spreader Barge System Placing Sand Cap Materials.

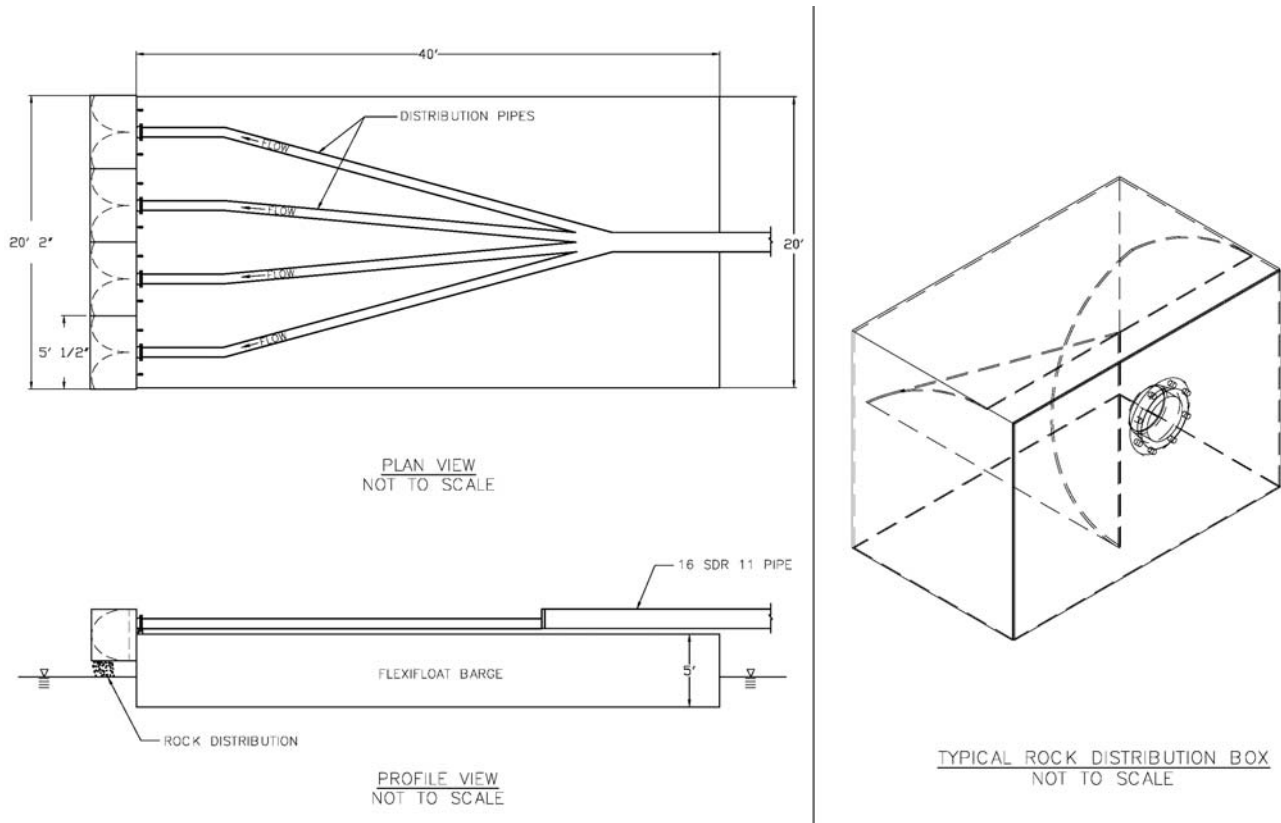

Figure 2. Schematic of the SES Spreader Barge for Armor Stone Placement



Figure 3. Slurry Feed System that Transport Materials to the Spreader Barge

The anticipated production rate that Severson calculated for each cap area is based on the pumping distance to the site from the shoreline and any inefficiencies associated with moving anchors, maintenance, shift changes, weather delays, fueling, and material stockpiling logistics. The anticipated uptime is estimated to be 80% of a 24 hour work day.

Table 1 below details the range of production rates for hydraulic placement of sand materials.

SAND HYDRAULICALLY PUMPED

Remediation Area	Min Pumping Distance (Ft)	Max Pumping Distance (Ft)	Theoretical Min Prod. Rate ^a (Cy/Hr)	Theoretical Max Prod. Rate ^a (Cy/Hr)	Anticipated Prod. Rate (Cy/Day) ^b	Booster/Staging Location
A	1,100	4,300	550	630	2,073	Wastebeds/9 Mile Creek
B	2,100	4,700	500	630	2,073	Wastebeds/9 Mile Creek
C	1,700	5,100	450	630	2,073	Work Support Area
D	600	3,330	630	630	2,073	Work Support Area
E	2,200	5,500	400	630	2,073	Work Support Area

Notes:

- a. Estimated minimum and maximum production rates based on manufacturer’s estimates without consideration of inefficiencies related to loading the slurry hopper, achieving a consistent feed rate, time required to start and stop a given placement lane, mechanical delays, weather delays, etc.
- b. Anticipated production rate based on moving anchors, safe speed that cables can be winched onto the spools, maintenance, shift changes, weather delays, fueling, and material stockpiling logistics

The anticipated production rate of approximately 108 CY/HR (2,073CY/Day) was developed based on safe operating speeds of the capping barge, equipment limitations of safe winching speeds, feeding the slurry system with a consistent feed to minimize overspreading materials and minimize barge “jerking” through the water with the cap automation system.

Characteristics and efficiencies for pumping the sand materials are:

- Velocity in the pipeline to pump a medium sand will be 16 to 18 feet per second
- Flow rate will be approximately 7,500 gpm
- Pump revolutions per minute (RPMs) will range from 500 to 680 depending on pumping distance
- Pump HP used will range from 500 to 900 depending on pumping distance
- Keeping barge movement limited to less than 20 feet per minute

Table 2 below details the anticipated range of production rates for hydraulic placement of armor stone materials less than 2 inches in diameter.

ROCK UP to 2 INCHES HYDRAULICALLY PUMPED

Remediation Area	Min Pumping Distance (Ft)	Max Pumping Distance (Ft)	Theoretical Min Prod. Rate ^a (Cy/Hr)	Theoretical Max Prod. Rate ^a (Cy/Hr)	Anticipated Prod. Rate ^b (Cy/Day)	Booster/Staging Location
A	1,100	4,300	95	304	960	Wastebeds/9 Mile Creek
B	2,100	4,700	90	304	960	Wastebeds/9 Mile Creek
C	1,700	5,100	80	304	960	Work Support Area
D	600	3,330	155	304	960	Work Support Area
E	2,200	5,500	50	304	960	Work Support Area

Notes:

- Estimated minimum and maximum production rates based on manufacturer’s estimates without consideration of inefficiencies related to loading the slurry hopper, achieving a consistent feed rate, time required to start and stop a given placement lane, mechanical delays, weather delays, etc.
- Anticipated production rate based on moving anchors, safe speed that cables can be winched onto the spools, maintenance, shift changes, weather delays, fueling, and material stockpiling logistics

The anticipated production rate of approximately 50 CY/HR (960 CY/Day) for armor stone up to 2 inches in diameter was developed based on safe operating speeds of the capping barge, equipment limitations of safe winching speeds, feeding the slurry system with a consistent feed to minimize overspreading materials and minimize barge “jerking” through the water with the cap automation system.

For placement of sand and armor stone less than 2 inches in diameter, Severson plans to use two spreader barge systems. It is anticipated that each barge system will operate 24 hours per day. Two crews will be required per spreader system each day. Each crew will work 12 hours per day. Severson anticipates an uptime of 80%. The anticipated 80% uptime and 20% downtime was calculated based on potential delays associated with setting anchors, weather delays, mechanical delays, fueling, greasing and routine maintenance.

Characteristics and efficiencies for pumping the armor stone materials up to 2 inches in diameter are:

- Velocity in the pipeline to pump a medium sand will be 14 to 18 feet per second
- Flow rate will be approximately 6,000 to 7,500 gpm
- Pump RPMs will range from 500 to 700 depending on pumping distance
- Pump HP used will range from 500 to 900 depending on pumping distance
- Keeping barge movement limited to less than 15 feet per minute

6.3 Armor Capping Operations

For the mechanical placement of armor materials larger than 2 inches in diameter, Severson will use one hydraulic excavator (Komatsu PC 300) stationed on a modular Flexifloat barge. The details of the placement system are:

- Aftermarket boom and stick capable of reaching 47 feet.
- Flexifloat barge 40 feet wide and 60 feet long (six assembled Flexifloat barges each measuring 10 feet by 40 feet).
- Draft of the barge with excavator will be approximately 2 feet.
- DREDGEPACK® software system, RTK GPS.
- Seven inclinometers for the boom, stick, bucket, and rocking of the barge.
- Real time water surface elevation display in the cab.
- A 2 CY clamshell bucket will be used to place material. The bucket will be similar to an environmental clamshell.
- Cycle times are anticipated to be approximately 45 seconds to 2 minutes depending on the complexity of the placement, material type, water depth, location of stockpile material (i.e. supply barge on the hip or located to the stern because of draft limitations)



Figure 4. Mechanical Placement of Rock Cap Materials from a Shallow Draft Barge

Production rates for mechanical placement of armor materials larger than 2 inches in diameter are calculated to be approximately 50 CY/HR. These production rates account for uptime/downtime, repositioning barges, etc. Severson plans to operate 2 crews each working two 12 hour shifts. Severson anticipates an uptime of 80%.